

From INSPIRATION to REALIZATION...

INTELLIGENT AUDIO-VIDEO AUTOMATIC

**RAVELL®**



PRODUCT  
CATALOGUE 2014/2015



# RAVELL®

The RAVELL® brand was established in 1999. It contains a wide spectrum of mounting solution for A/V equipment.

We use only EU made parts and components.

High quality and reliability of RAVELL® products gives comfort to our customers. We specialize in integrating modern audio - video systems.

**RAVELL®**  
**From INSPIRATION to REALIZATION ...**  
**Intelligent audio – video automatic** ▶▶

We specialize in unusual, exclusive and niche products. We make unique products, by taking original challenges. This makes our brand very strong competitive and gives us a good position on the market.

We invite you to get acquainted with the wide variety of RAVELL® products.

## PROJECTOR MOUNTS

UNIVERSAL MOUNTS ————— 3

DEDICATED MOUNTS ————— 5

## PROJECTOR LIFTS

CEILING LIFTS ————— 7

- standard lifts

- slim lifts

TABLE / FURNITURE LIFTS ————— 9

WALL LIFTS ————— 11

## TV MOUNTS

WALL MOUNTS ————— 13

CEILING MOUNTS ————— 15

FLOOR MOUNTS (STANDS) ————— 17

ELECTRIC MOUNTS ————— 19

## TV LIFTS

MEBLOWE FLOOR / FURNITURE LIFTS ————— 21

CEILING LIFTS ————— 23

HORIZONTAL LIFTS ————— 25

## SPECIAL CONSTRUCTIONS

FRAME SYSTEMS FOR VISUAL WALLS ————— 27

PIVOTING PANELS / WALLS ————— 29

**RAVELL** ————— 31

**RAVELL®**



**UNIVERSAL PROJECTOR MOUNTS**





### UNIVERSAL PROJECTOR MOUNTS

The RAVELL® universal projector mounts provide easy and stable installation of multimedia projectors under the ceiling. This solution secures optimal settings of the displayed image.

#### APPLICATION

- STANDARD version for projectors up to 10 kg
- MAX version for projectors up to 25 kg

#### MOUNT CONTAINS

- ceiling mounting base
- under ceiling arm
- universal projector mount
- necessary installation elements

#### MAIN FEATURES

- height range: 45-100 cm (or custom)
- height regulations: stepwise
- reliable and functional construction made of high quality steel
- easy set up and full three-dimensional regulation (precision correction on threaded sleeve)
- cable passage inside the arm
- covering in black, white, silver powder coating (or custom – other colours available; from RAL palette)
- aesthetic and precise finish

**RAVELL®**



**DEDICATED PROJECTOR MOUNTS**





### DEDICATED PROJECTOR MOUNTS

The RAVELL® dedicated projector mounts are made especially for specific devices to work with.

#### APPLICATION

- for heavy weight multimedia projectors with special mounting needs
- for unusual, architectural or installational solutions

#### THE MOUNT`S COMPONENTS

- wall / ceiling base
- under ceiling / wall arm
- dedicated projector mount
- necessary accessories

#### MAIN FEATURES

- height range: according to user needs
- height regulations: smooth or stepwise
- certain and functional construction made of high quality steel
- easy setup and three dimensional regulation  
(precision correction on threaded sleeve)
- cable passage inside the arm
- optional : A ball joint for easy installation in difficult surroundings
- covering in black, white, silver powder coating (or custom – other colours available; from RAL palette)
- aesthetic and precise finish

**RAVELL®**



**CEILING PROJECTOR LIFTS**







### CEILING PROJECTOR LIFTS

The RAVELL® ceiling lift lowers the multimedia projector suspended from the ceiling to its working position. It increases the aesthetic appearance of the room, causing the projector to remain invisible until it is in use.

Additionally, the projector is protected from unwanted operations.

#### APPLICATION

- STANDARD, for business solution – operating range 0-700 cm
- SLIM, for home cinema – operating range 0-80 cm

#### ADDITIONAL ACCESSORIES

- required length assembly spacers.
- wireless control IR or RF
- projector masking
- safety and precision is guaranteed by a double limit switch system
- easy to operate

#### MAIN FEATURES

- construction based on a three-horizontal-frame system - the system is moved by a precise, single or double scissor lift
- low speed winch with winding lowers and lifts the construction
- 100% repeatability
- silent and smooth rope drive
- covering in black, white, silver powder coating (of custom – other colours available; from RAL palette)
- aesthetic and precise finish



**TABLE / FURNITURE LIFTS**



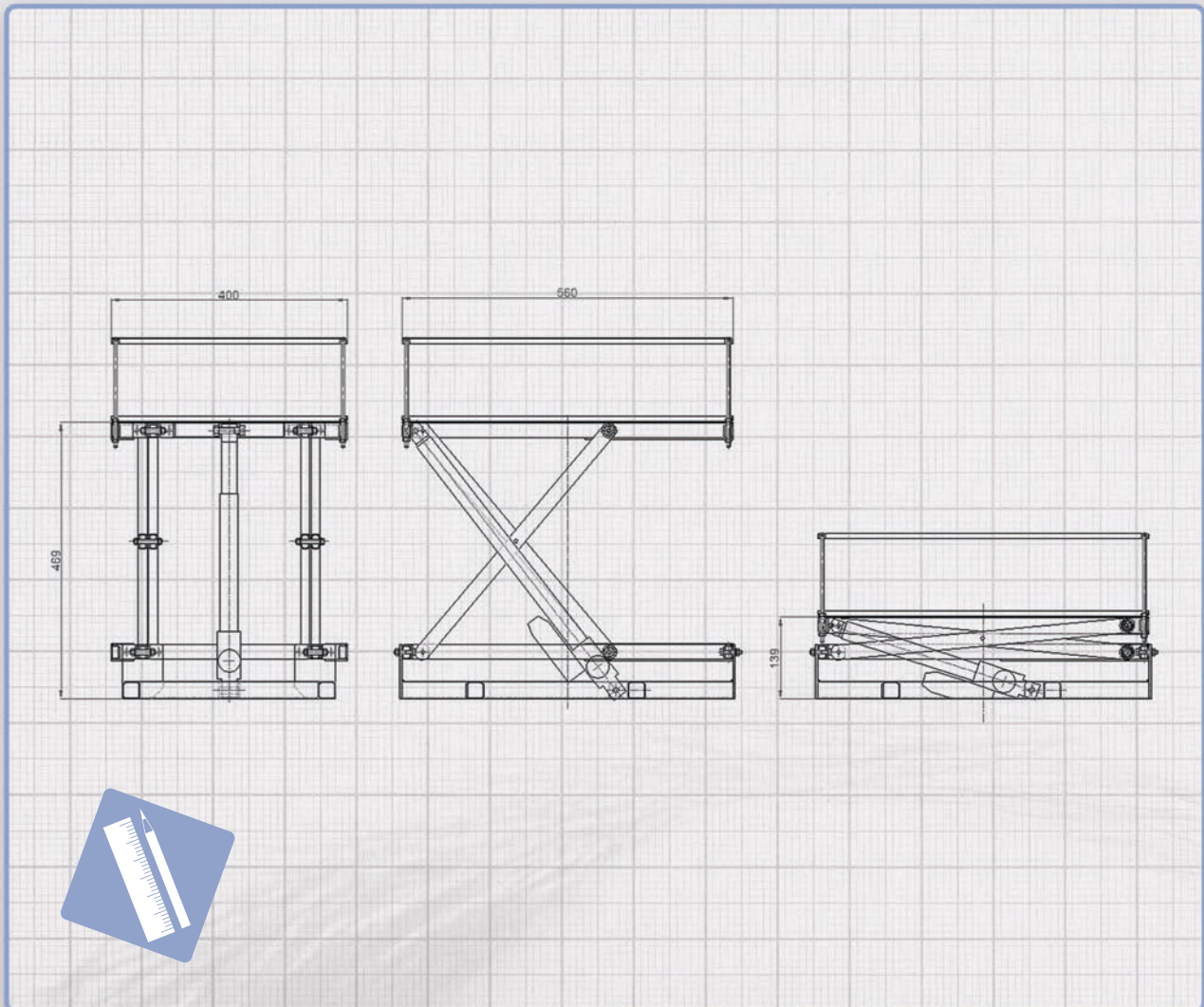

### TABLE / FURNITURE LIFTS

The RAVELL® furniture/table lift for multimedia projectors is an excellent alternative for ceiling lifts. It allows installation of the multimedia projector inside the furniture or in the floor.

This solution is mostly used by architects in designing domestic space or public institutions.

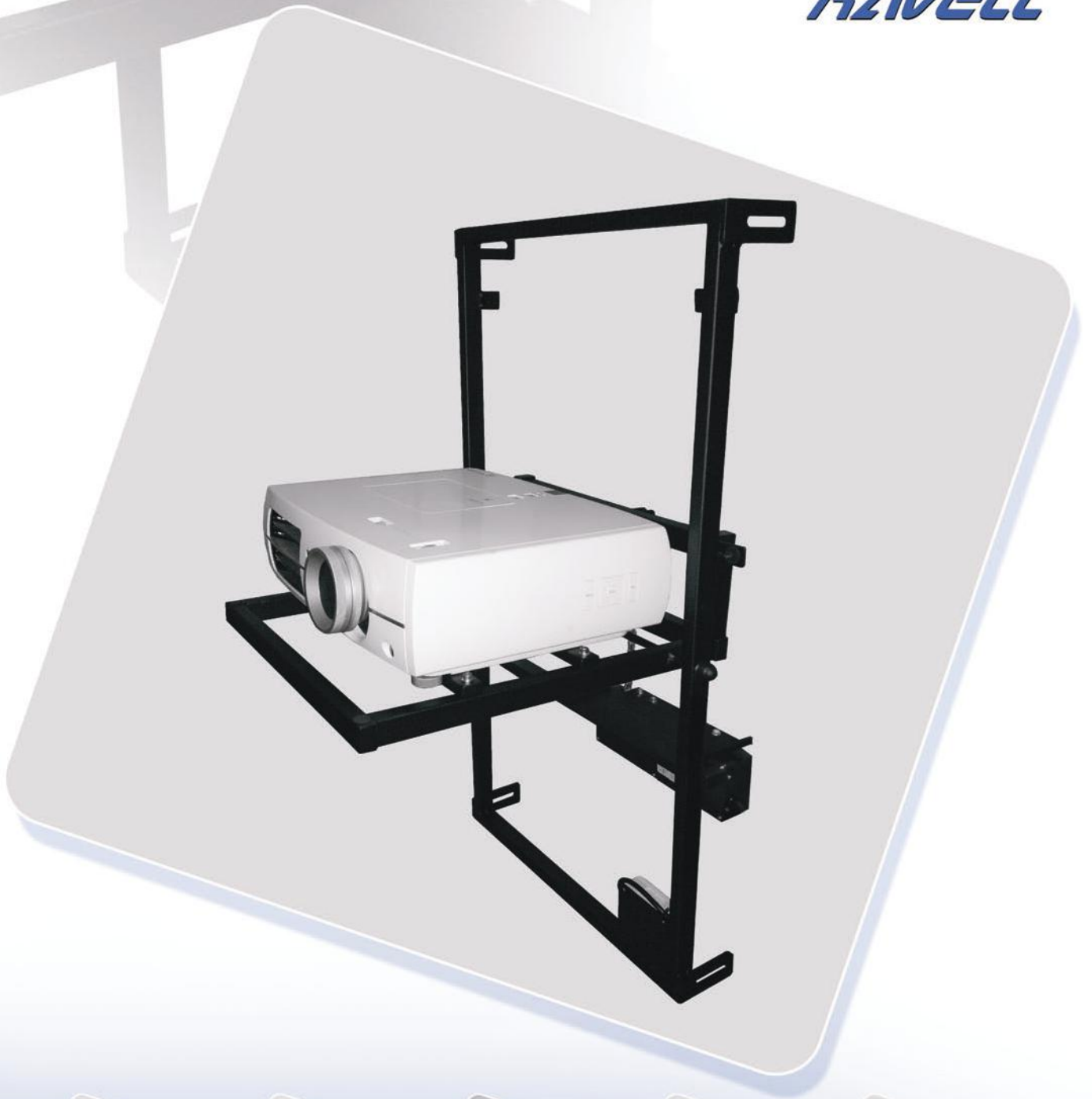

**WALL PROJECTOR LIFTS**



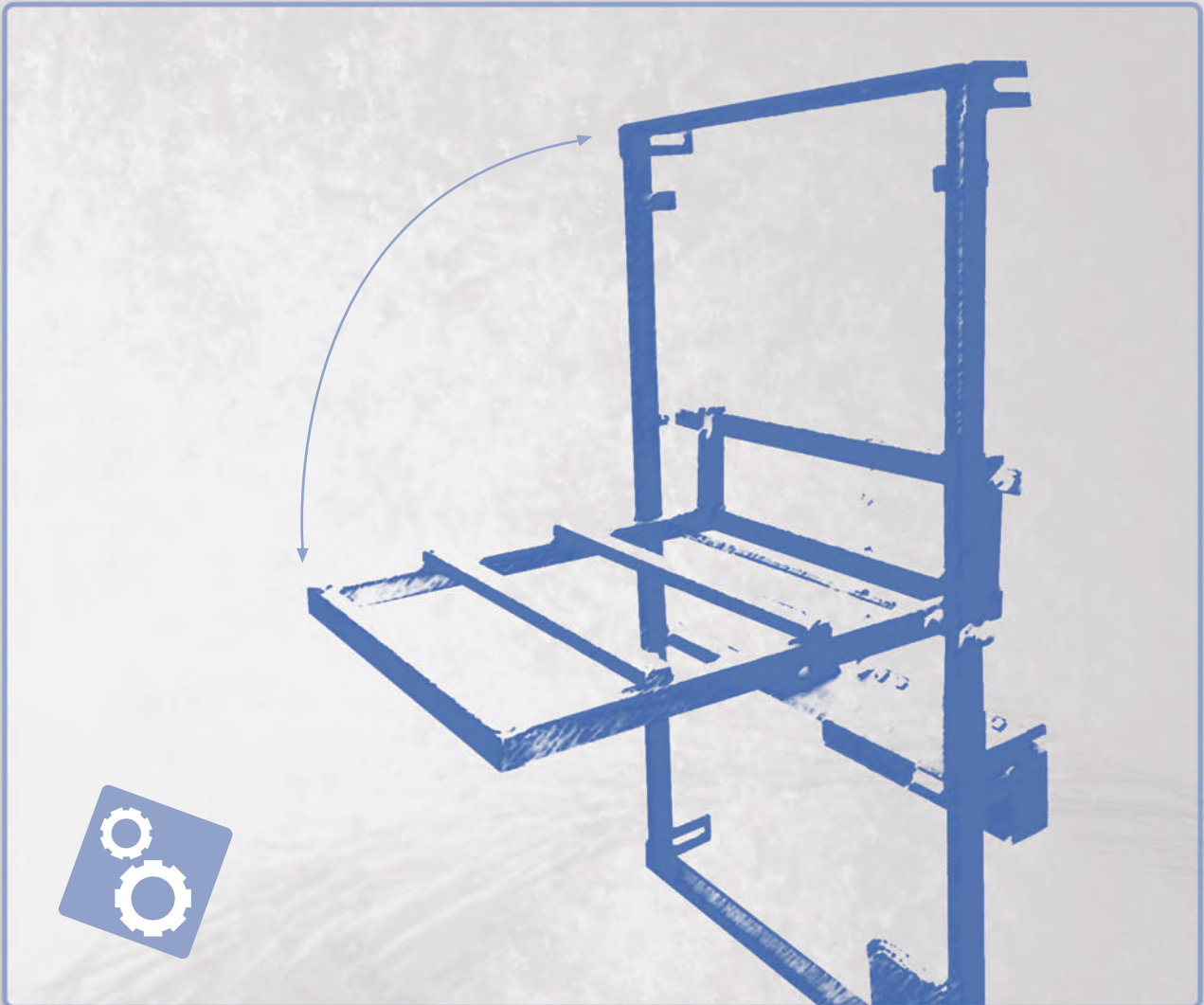

### WALL PROJECTOR LIFTS

The RAVELL® wall projector lift allows to hide a multimedia projector inside the wall or in furniture. The projector is only visible during use.

Usage of system does not disrupt the aesthetics of the room. The wall lift is a great solution for people who want to make effective use of small spaces.

**RAVELL®**



**UNIVERSAL TV MOUNTS**





## UNIVERSAL TV MOUNTS

The RAVELL® universal mounts ensure easy installation on the wall and are very reliable.

### AVAILABLE IN FOUR VERSIONS

- RAVELL STANDARD VESA up to 600x400 mm with accidental fall protection
- RAVELL MAXI for Tv up to 65``, VESA up to 800x400 mm with accidental fall protection
- RAVEL TILTING VESA up to 600x400 mm with accidental fall protection - vertical tilt 0-22degrees
- RAVELL SWIVELL VESA up to 600x400 mm with accidental fall protection - horizontal inclination 0-90 degrees

### MOUNT CONTAINS

- wall frame based on a creased sheet metal - made of high quality steel
- mounting hooks with protection – attached to a TV or monitor

### MAIN FEATURES

- reliable and functional construction made of high quality steel
- easy installation
- multifaceted regulations system, for easy set up with a TV or monitor
- covering in black powder coating (or custom – other colours available; from RAL palette)
- aesthetic and precise finish

**RAVELL®**

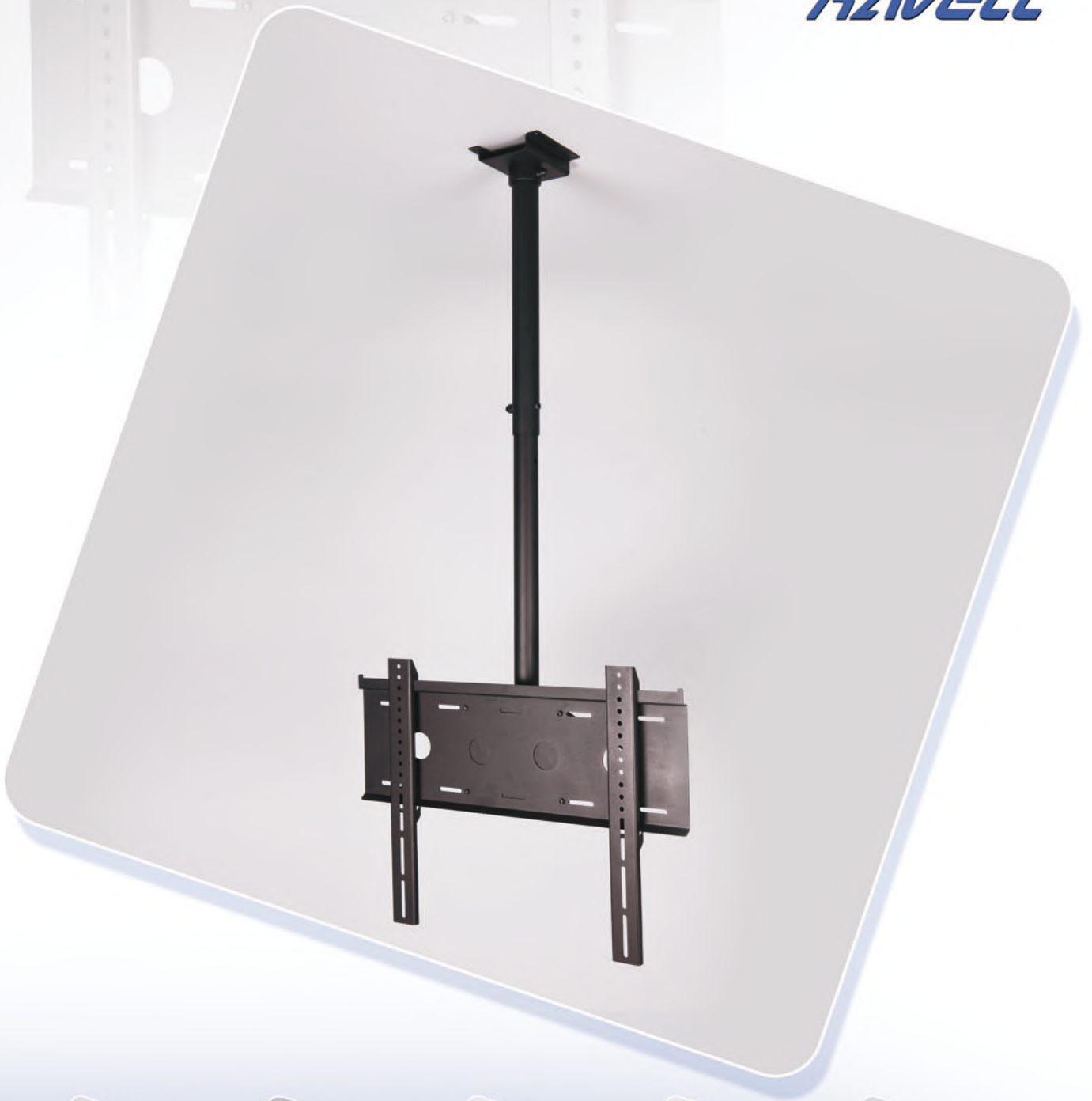

**TV CEILING MOUNTS**







## TV CEILING MOUNTS

With the RAVELL® universal mounts you can install your TV or monitor under the ceiling. They are compatible with almost every known TV/Monitor brand. Up to 60`` diagonaly. The fact that all RAVELL® ceiling mounts are custom made gives us the chance to modify the product to specific or unusual installation circumstances.

### MOUNT CONTAINS

- ceiling mounting base
- underceiling arm
- universal TV/monitor mount
- necessary installation accessories

### MAIN FEATURES

- height range: 100-160 cm (or custom)
- height regulations: stepwise
- reliable and functional construction made of high quality steel
- easy set up and three dimentional regulation
- cable passage inside the arm
- covering in black powder coating (or custom – other colours available; from RAL palette)
- aesthetic and precise finish

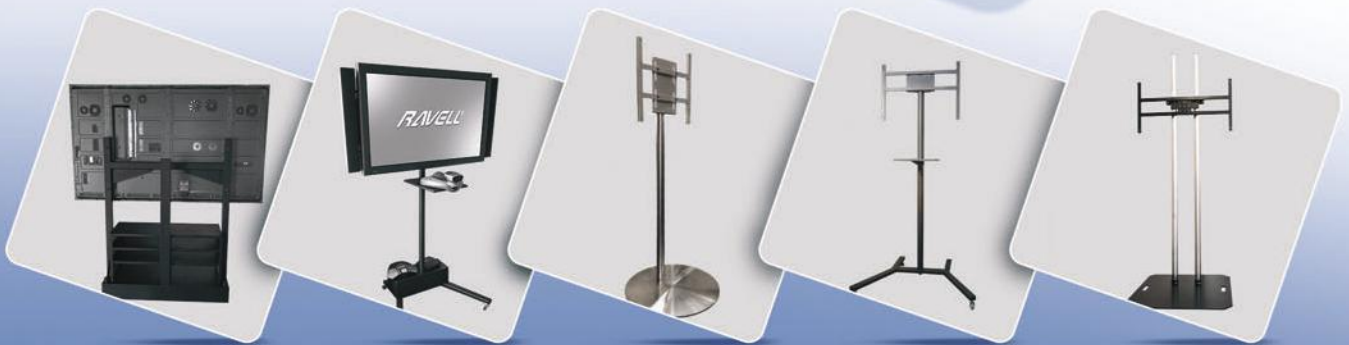

**FLOOR TV MOUNTS (STANDS)**



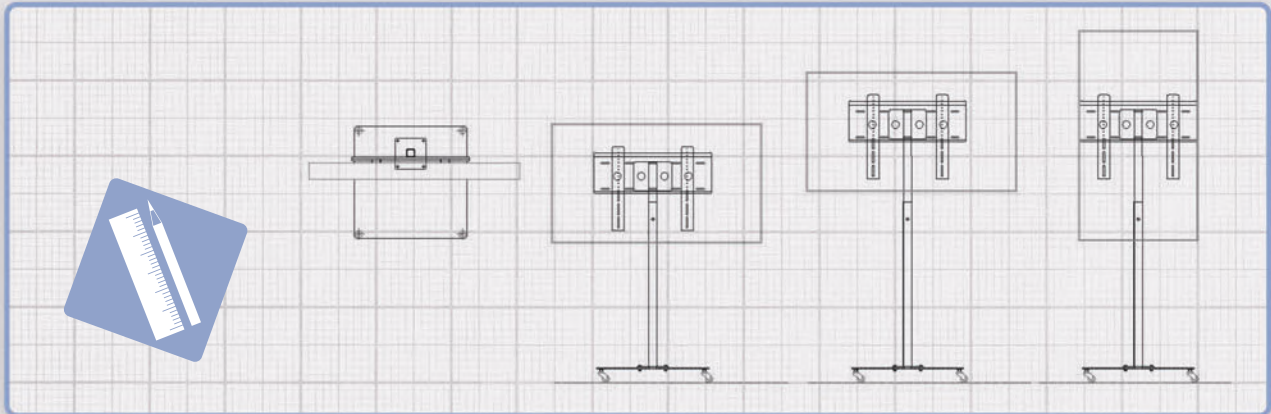

## FLOOR TV MOUNTS (STANDS)

The RAVELL® floor stands are made in accordance with a particular users needs. That means specified preferences of design and functionality, such as the height of the construction and proper TV or monitor mount.

### TWO VARIANTS OF THE TV STAND BASE

- based on one or two regulated legs, with pivoting-blocking wheels
- solid, finished with brushed steel elements

### APPLICATIONS

- stands equipped with regulated, moving bases are mostly used in institutional solution
- solid stands are meant for home solution
- covering in black, white, silver powder coating (or custom – other colours available; from RAL palette)

**RAVELL®**



**ELECTRICAL TV MOUNTS**



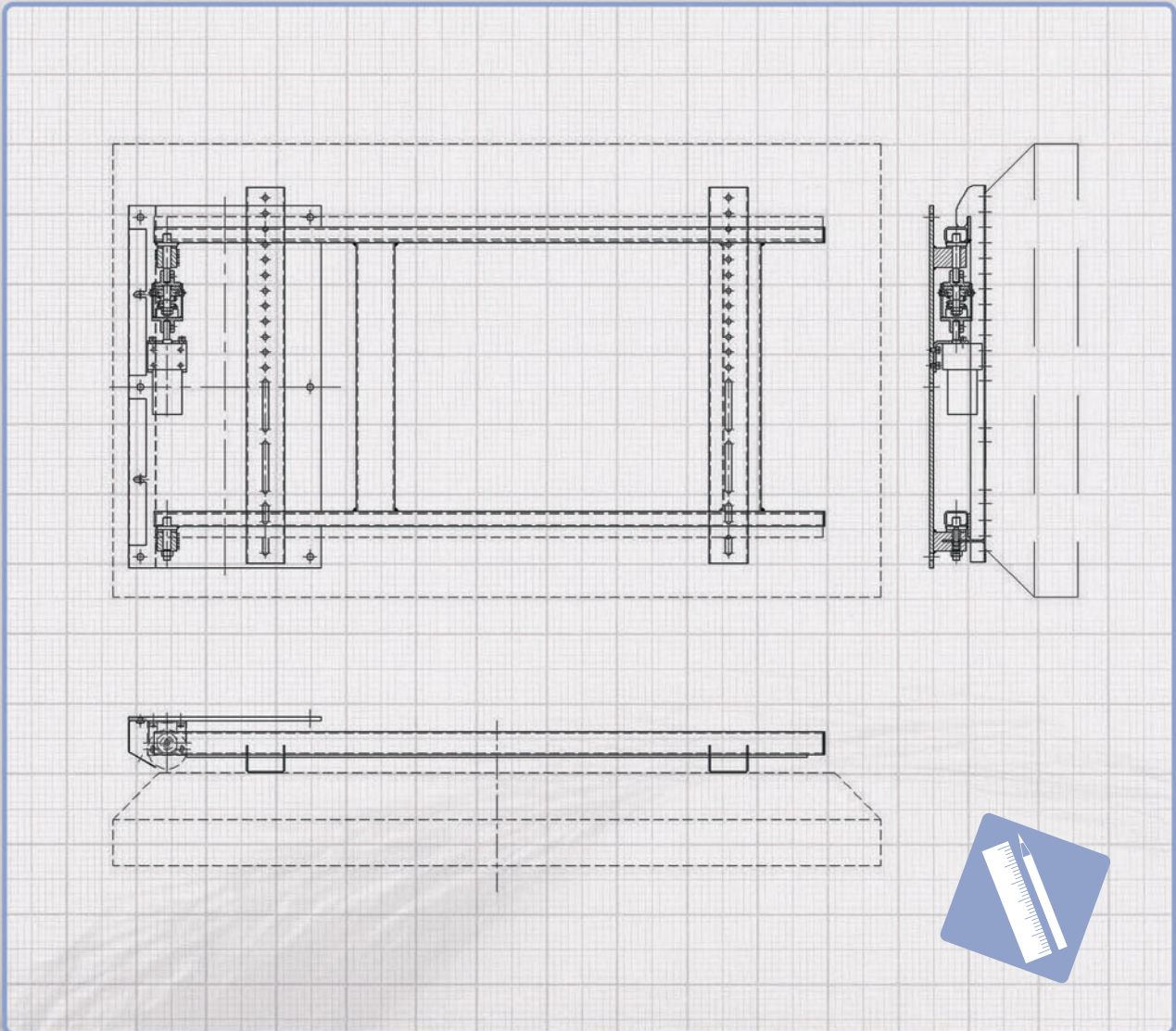

## ELECTRICAL TV MOUNTS

The RAVELL® electrical TV mounts are made for TV or monitors up to 60" and allow for electrical horizontal or vertical regulations.

You can lean the TV (monitor) along the vertical edges or you can move it left/right along the mounting base.

**RAVELL®**



**FLOOR / FURNITURE LIFTS FOR TV**





## FLOOR / FURNITURE LIFTS FOR TV

TV/monitor lifts are mechanisms for ejecting screens out of furniture for use.

When the TV is not in use, it can be lowered and become invisible. The furniture lift can operate with TV's or monitors from 22`` up to 60``. The design of the lift makes it very easy to assemble inside the furniture or cavity.

### APPLICATION

- LIFT TV-670 for TV/Monitor 22`` - 40`` diagonal
- LIFT TV-980 for TV/Monitor 42`` - 60`` diagonal

### MAIN FEATURES

- mechanism made of highest quality components with every technical novelty
- silent, smooth mechanism, based on column line or rope drive
- many protective mechanisms and sensors
- manual contro - option: wireless IR or RF
- equipped with universal TV/monitor mount. VESA standard 600x400 mm
- on demand: dedicated Tv/monitor mount for a specific models
- easy control
- compatibility with almost every known Tv/monitor model
- aesthetic and precise finish

**RAVELL®**



**CEILING TV LIFTS**







## CEILING TV LIFTS

The RAVELL® ceiling TV lifts are dedicated to TV's or monitors 32" up to 60".

The design of the lift allows you to install the lift on the ceiling and lower it down. After you can tilt the screen to a desired position.

### AVAILABLE IN TWO VARIANTS

- lowering vertical lifts
- tilting lifts

### MAIN FEATURES

- mechanism made of highest quality components with every technical novelty
- silent, smooth mechanism, based on linear actuators or rope drive (depends on the use)
- many protections and sensors
- easy control
- compatibility with almost every known TV/monitor model
- aesthetic and precise finish

**RAVELL®**



**HORIZONTAL TV LIFTS**



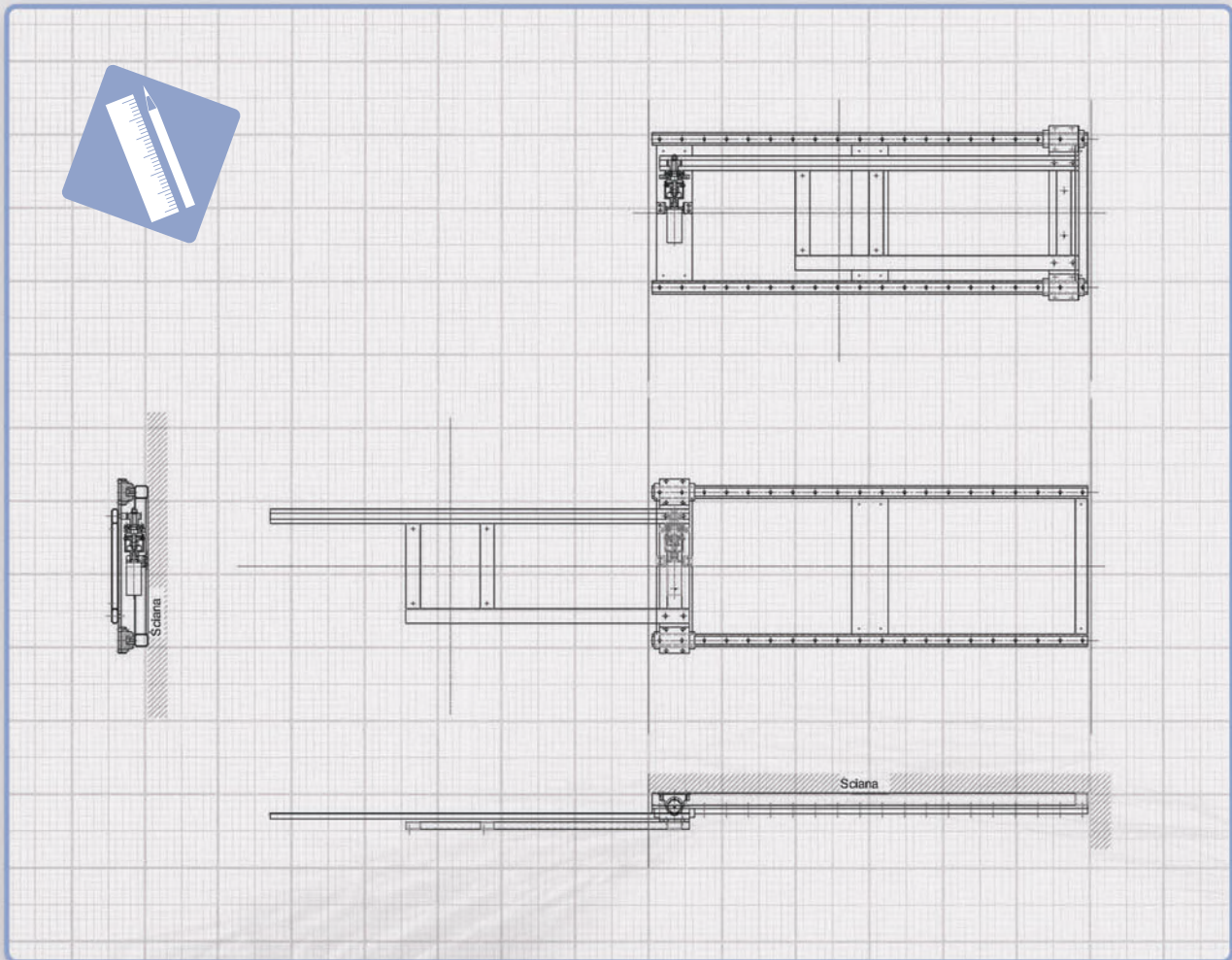

## HORIZONTAL TV LIFTS

Professional mechanisms made from highest quality components. Exceptional care during the production process. This is the RAVELL® brand. The TV horizontal lifts are equipped with a silent and smooth mechanism which can move the TV out from the side of the furniture, wall or construction (horizontally).

A number of safeguards and sensors guarantee safe control of the unit.

Reliability, functionality, and the possibility to create remarkable interior design, are the advantages of this equipment.

**RAVELL®**

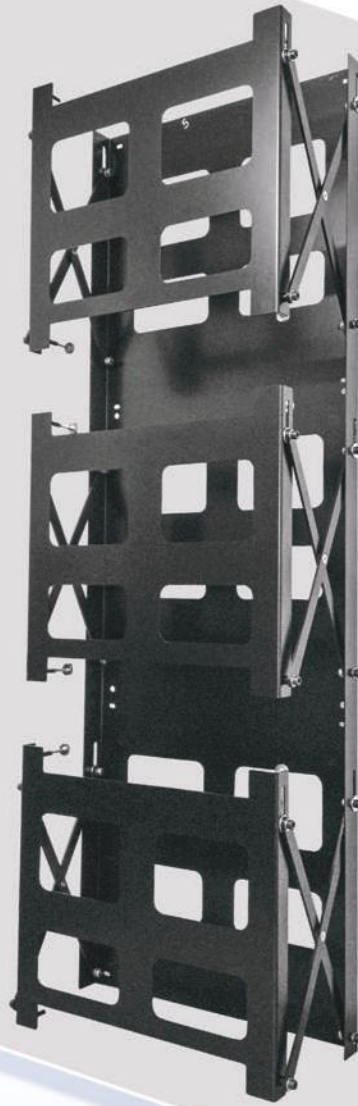

**FRAME SYSTEMS FOR VISUAL WALLS**





### FRAME SYSTEMS FOR VISUAL WALLS

Frame systems for visual walls are mostly made up of several monitors in different configurations, 2x2 or 3x3 for example. This solution gives the possibility for diagonal the screen diagonally.

#### SCREEN WALLS ARE MANUFACTURED IN TWO VARIANTS

- static constructions
- mobile constructions

#### MAIN FEATURES

- easy installation
- multifaceted regulations system, for easy set up
- reliable and functional construction made of high quality steel
- covering in black powder coating (or custom – other colours available; from RAL palette)
- aesthetic and precise finish

You can pull out a single monitor from the Ravell frame system for visual walls without disassembling the whole set.

Mobile-screen wall constructions are easy to move, according to user needs (optional regulations of height).



**PIVOTING PANELS / WALLS**





### PIVOTING PANELS / WALLS

Pivoting panels/walls can create interesting space arrangement. They can move the TV itself, the panel with TV attached or a part of the wall, even the whole wall. The rotation is smooth and silent. Control can be manual, radio or IR. The selection of the mechanism and the way to control it depends on the end user.

Ravell pivoting walls/panels can be easily integrated with existing installations as a part of „intelligent building“ control.



**RAVELL®**







## RAVELL®

RAVELL® is the answer to a growing need and demand of the customer. Based on a 15 year experience, our knowledge and sense of clients preferences gives us the certainty that our construction and finishing standards are very high. We are the perfect audio-video mounting solution.

---

The high quality of systems manufactured by us is based on care for the every detail both constructional and aesthetic.

---

Our solutions are directed at every kind of customer. Institutional (complex equipment of training, conference rooms) and individual (residential, home).

---

We cooperate with architects and carpenters. Any custom demand can be fulfilled.

---

The individual approach to each client and the understanding of his needs is what makes us stand out on the market.

---

From Inspiration To Realization. This is our motto.





**QUALITY GUARANTEED**



**RAVELL®**

... TO MAKE PICTURE  
A PIECE OF ART



**RAVELL®**

[www.ravell.com.pl](http://www.ravell.com.pl)

DISTRIBUTOR

